

## Assembly instructions anti-slip plates Double-Minitramp

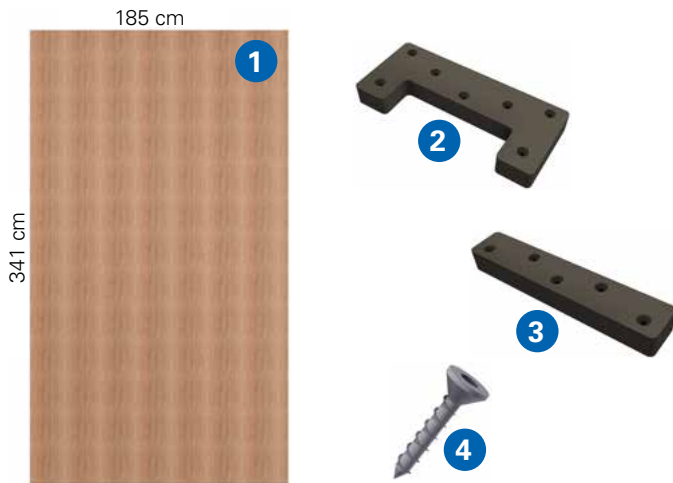

### Parts list:

- 12 mm multiplex board, 3-part with puzzle connection: 2x 112,3x185 cm + 1x 116,4x185 cm = total 341x185 cm (Fig.1)
- 8 pc. Mounting block type 1 (Fig. 2)
- 4 pc. Mounting block type 2 (Fig. 3)
- 76 pc. Wood screws 3.5\*25 (Fig. 4)
- 5 m<sup>2</sup> double-sided tape (z.B. 4\*50 mm roll of 25 m EAN 4042448388704)

### Process:

- Carefully clean the surface on which the DMT is to stand (free of dust and grease).
- Apply the double-sided tape over the entire surface of a clean side of the assembled multiplex board (e.g. in longitudinal strips).
- Pull the protective backing off of the tape and adhere the multiplex board to the clean surface.
- Align the Double-Minitramp to the multiplex board and set it at the specified height relative to the floor (not the wooden board).
- Check the chain tension and adjust as necessary.
- Screw 2 pc. type 1 mounting blocks onto the front and rear feet from above as pictured. The foot protector of the trampoline should be surrounded as closely as possible without play.
- Use the type 2 mounting blocks to fix the centre feet to the front and rear.

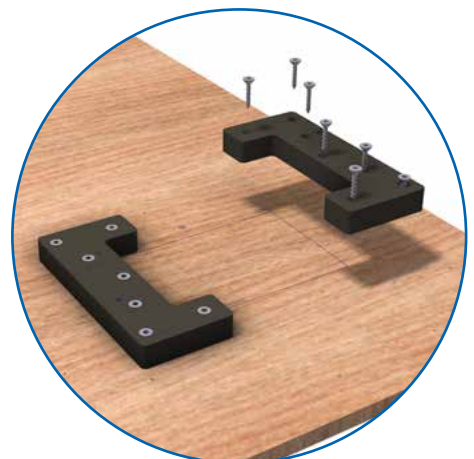
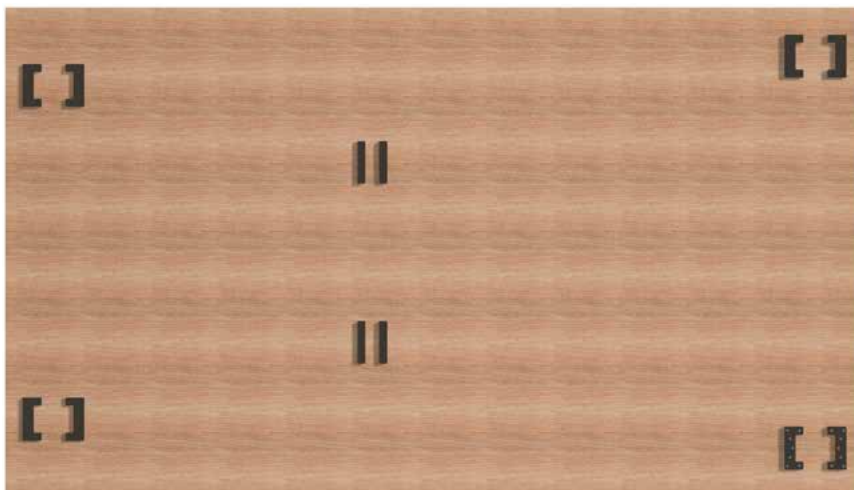

**Note:**

- If the multiplex board will be attached to a wood surface (e.g. wooden platform), the adhesive is not necessary and the wooden board can instead be screwed into the subsurface. Longer screws can also be used in the mounting blocks.
- The multiplex board is designed for one-time use and will be difficult to remove from the floor without damaging it.
- The mounting blocks are designed for reuse.

**Alternatives:**

- If no Eurotramp mounting blocks are available, simply use square timber. Ensure the screws are the correct length and do not penetrate the subsurface.

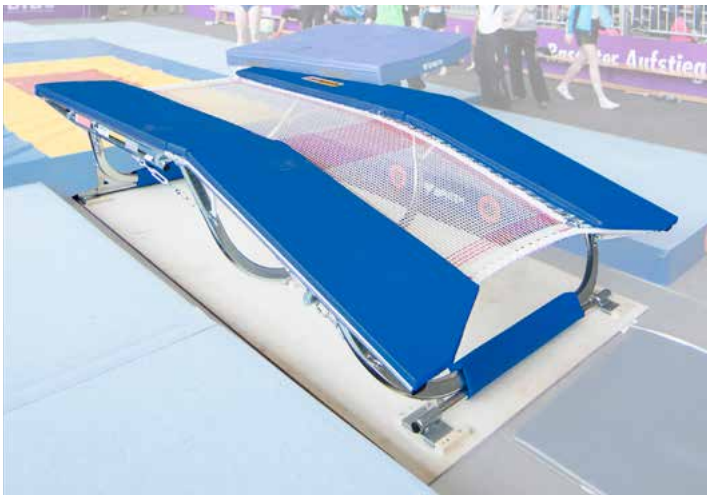

✔ **Done!**

**If you have any questions, contact us any time:**

**Eurotramp Trampoline - Winam**

84 961610202

Room 101, No. 226 / 4A Le Trong Tan, Tay Thanh Ward, Tan Phu District, Ho Chi Minh City, Vietnam

[info@eurotramp.com.vn](mailto:info@eurotramp.com.vn)